

The 2022 Bolt EUV and Bolt EV



NEW AND IMPROVED

The 2022 Chevrolet Bolt EUV is an all-new electric vehicle that builds on the success of the Chevrolet Bolt EV, with a 6-inch (15.2 cm) longer overall length and a crossover-style body. Both the 2022 Bolt EUV and 2022 Bolt EV feature a new interior, a number of innovative features and sleek exterior designs, while sharing the same 65kWh nickel-lithium-ion high-voltage battery pack.



2022 Bolt EUV and Bolt EV High-Voltage Battery Assembly

see page 5

<i>New and Improved: The 2022 Bolt EUV and Bolt EV</i>	1
<i>Report Concerns to the 2022 Bolt EUV and Bolt EV TAC Action Center</i>	7
<i>Electronic Transmission Range Selector Assembly Parts Return</i>	8
<i>Proper Key Fob Inspection and Battery Replacement</i>	9
<i>Wireless Phone Charging Option No Longer Available on Some 2021 Models</i>	10
<i>3.6L Engine Intake Camshaft Position DTCs</i>	10
<i>Heater Outlet Pipe Coolant Leak</i>	11

CONTINUED ON PAGE 2

New and Improved: The 2022 Bolt EUV and Bolt EV

Both vehicles share an all-electric front-motor, front-wheel-drive, 5-passenger, 4-door design. The new Bolt EV is available in two trim levels: 1LT and 2LT, while the Bolt EUV is available in three trim levels: LT, Premier, and the limited Launch Edition.

The new design of both vehicles features an advanced high-strength steel frame and aluminum enclosures on the front fender, hood, door and liftgate for increased efficiency. The cabin has a 10.2-inch (259 mm) color touchscreen mounted in the center stack and a driver-facing 8.0-inch (203 mm) color digital gauge cluster.



2022 Bolt EUV cabin

PROPULSION SYSTEM

The Bolt EV and Bolt EUV are equipped with a 65-kWh nickel-rich, lithium-ion high voltage-battery. It weighs approximately 946 pounds (429 kg) and is an integral member of the vehicle's BEV II chassis, improving torsional rigidity by nearly 30 percent over the previous Bolt EV model.

The propulsion of the vehicle is achieved by a front-wheel drive, variable-speed 1ET25 automatic transmission (RPO MMF) and a permanent magnet 150-kWh drive motor controlled by a power inverter module, which provides torque for vehicle propulsion and regenerative braking. The Bolt EUV retains drive unit cooling using the power electronics coolant loop. The Bolt EV eliminated the drive unit cooler and hoses.

The Bolt EV offers an EPA-estimated 259 miles (417 km) of range per full battery charge and the Bolt EUV offers an EPA-estimated 247 miles (397 km) of range per full battery charge. Three range

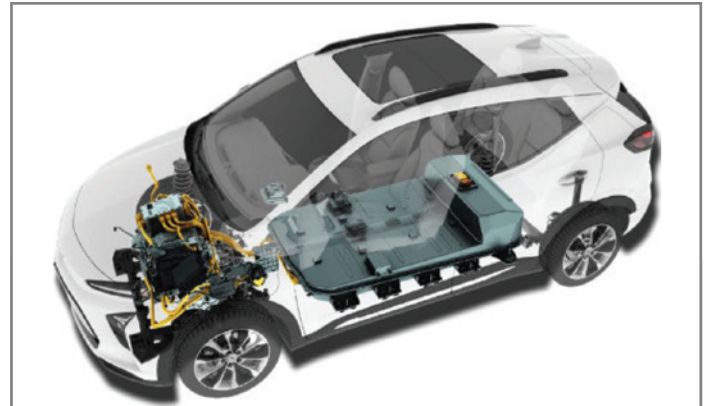

The high-voltage battery is an integral member of the vehicle's BEV II chassis.

estimates are displayed on the instrument cluster: a maximum, a minimum, and a more prominent best estimate based on the individual's driving style. Accessory usage, such as climate control settings and heated seats, as well as outside ambient conditions have a large effect on overall range.

ONE-PEDAL DRIVING

The electronic shifter features a push/pull switch operation. Park and Neutral require a button push while Reverse and Drive require a button pull. There is not a Low (L) selection.



The electronic shifter features a push/pull switch operation.

At the bottom of the electronic shifter is the One-Pedal Driving button that turns on the One-Pedal Driving mode, which helps

CONTINUED ON PAGE 3

the vehicle generate and capture greater amounts of energy that is used to charge the high-voltage battery during deceleration. One-Pedal Driving mode remains engaged over key cycles.

One-Pedal Driving mode does not eliminate the need to use the brake pedal altogether, especially in emergency situations. Progressively stronger levels of regenerative braking are employed through a series of four driver-selectable modes

1. Operating in Drive and easing off the accelerator. This first level provides the lowest level of regenerative braking and requires the use of the brake pedal to bring the vehicle to a complete stop.
2. Operating in Drive and using the Regen on Demand™ paddle on the back of the steering wheel. Pulling the Regen on Demand paddle enables the driver to initiate the regeneration process and capture kinetic energy to slow the vehicle and restore energy to the battery.
3. Operating in Drive with One-Pedal Driving turned on and easing off the accelerator.
4. Operating in Drive with One-Pedal Driving turned on and using the Regen on Demand™ paddle in tandem.

These last three levels are progressively stronger One-Pedal Driving modes that, in certain driving situations, allow a driver to stop the vehicle without using the brake pedal. When in One-Pedal Driving mode, the rear brake lights illuminate automatically and stay on even after the car comes to a complete stop.



Regen on Demand paddle on the back of the steering wheel.

One-Pedal Driving will not function if the high-voltage battery is fully or near fully charged, and/or if the battery itself is very cold. The target charge level of the high-voltage battery can be adjusted in the energy screen to ensure that there is ample capacity in the battery to receive charging generated by the vehicle when Regen is active.

CHARGING THE VEHICLE

The standard level 1 drive motor battery charger cord included with the Bolt EV is capable of plugging into a standard 120V household electrical plug. Charge rates are either 8 amps or up to 12 amps.



Level 1 and level 2 charging are available.

A dual-mode drive motor battery charger cord, or dual-level charge cord, (RPO EKT) is standard equipment for the Bolt EUV and is optional for the Bolt EV. It features a swappable 120V standard household electrical plug and a 240V NEMA 1450 electrical plug, allowing for level 1 and level 2 charging. The charger also features a charge current interrupt device with AC power and fault indicators.

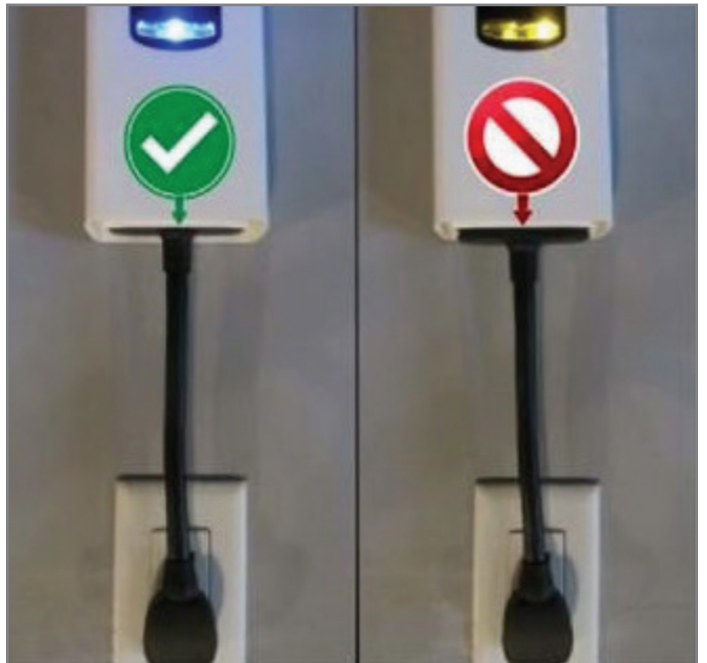

Make sure the dual-level cord set is fully seated.

TIP: If the pluggable cord set is not fully seated, the amber light will glow and the charger will not function. Fully seat the cord set.

CONTINUED ON PAGE 4

The charging system may run fans and pumps that result in sounds from the vehicle when it is turned off. Additional unexpected clicking sounds may be caused by the electrical devices used while charging. The Content Theft Deterrent system arms when the cord is plugged in and the vehicle is locked only when using level 1 charging.

DRIVER/ENERGY INFORMATION

The instrument cluster layout can be changed using the right steering wheel controls. There are two main cluster display configurations. The information on the left side of the Driver Information Center on the cluster generally provides battery and range information and the right side provides driving efficiency information.



The instrument cluster layout can be changed using the right steering wheel controls.

The driving scorecard rates things like driving technique, climate control usage, terrain and outside temperature. The range displayed in the vehicle is a prediction based on past driving conditions (kWh of energy used per distance traveled), current ambient temperature, and climate control settings. It is normal for the displayed value to adjust while the vehicle is being driven as this number is constantly being recalculated to provide the best estimate of electric range. The 2022 Bolt EV and EUV

provides helpful energy graphic displays and information in the center stack energy screen, or “leaf screen”.



Energy graphics are displayed in the center stack energy screen, or “leaf screen.”

DRIVER ASSISTANCE

The 2022 Bolt EV and Bolt EUV include the Chevrolet Safety Assist package as standard equipment. It includes Automatic Emergency Braking, Forward Collision Alert, Front Pedestrian Braking, Following Distance Indicator, Lane Keep Assist with Lane Departure Warning and IntelliBeam auto high beams.

Additional available safety features include HD Surround Vision, Lane Change Alert with Side Blind Zone Alert, Rear Cross Traffic Alert and Rear Park Assist.

TIRES

The vehicles are equipped with Michelin self-sealing tires. The vehicles do not come with an inflator kit (with the exception of vehicles sold in Rhode Island and Canada).

For additional information on the new 2022 Bolt EUV and Bolt EV, refer to Bulletin #21-NA-141.

► Thanks to Jonathan Johnson and Matt Bunting



2022 BOLT EUV AND BOLT EV

HIGH-VOLTAGE BATTERY ASSEMBLY

The 2022 Bolt EV and 2022 Bolt EUV are powered by a 65-kWh nickel lithium-ion high-voltage battery. The battery pack will be serviceable and some of the battery pack's accessory components have been fitted under the front hood for easier access and maximum space efficiency.

The drive motor battery contains 5 battery cell sections, a battery contact assembly, high-voltage bus bars, a manual service disconnect, and a Battery Energy Control Module. The 288 individual lithium-ion battery cells of the drive motor battery are rated at approximately 3.65 volts each. A protective polymer-

TIP: The high-voltage battery pack will be on TAC Restriction and Exchange during the vehicle launch period. However, the individual section are not on exchange. Only trained technicians with the proper knowledge, tools and Personal Protective Equipment (PPE) should inspect, test and/or replace the high-voltage battery.

BATTERY CELLS

An individual cell is configured horizontally with the negative tab on one end and the positive tab on the other. Each cell measures approximately 338 x 100 millimeters (mm), or 13.3 in x 3.9 inches (in), and weighs nearly 0.5 kilograms (kg) or 1 pound (lb.). Each battery cell contains a carbon anode (negative electrode), a nickel-rich lithium-ion chemistry cathode (positive electrode), and a safety-reinforced separator. The safety-reinforced separator provides the medium to transfer electrically charged ions between the anode and the cathode inside the battery cell.

BATTERY CELL GROUPS

Three cells are welded together in parallel to form 96 cell groups. These cell groups are clamped together in series to form 10 cell modules. Battery modules 5 and 7 have eight cell groups while the others contain 10. Two modules are physically assembled together to form a section, or row.

The modules are numbered 1 to 5 starting with the right forward-most module. Module 6 is in the rearward-most position on the left side, working forward to module 10. The cell groups increment in series, starting at the negative-most group 1 in module 1 and ending at cell group 96 in module 10. This is the typical numbering logic GM has adopted for most of their high voltage batteries, starting at the negative-most post and numbering the module to follow.

BATTERY CELL SECTIONS

There are five battery cell sections, or rows. The sections are numbered starting at the front with section 1 and ending with the upper-most section at the rear as number 5. The sections physically contain two modules each, but the modules are not electrically connected. Modules 5 and 6, however, are electrically connected through the manual service disconnect.

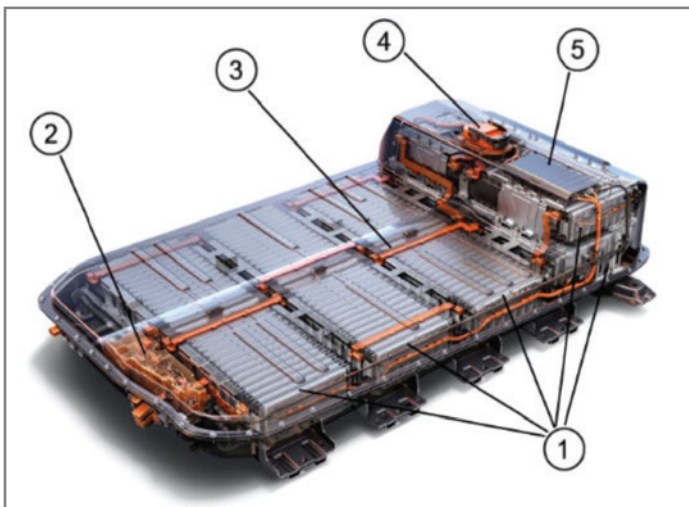

1. Battery Cell Sections (Rows)
2. Battery Contactor Assembly
3. High Voltage Bus Bars
4. Manual Service Disconnect
5. Battery Energy Control Module

coated aluminum cover encases each cell to help prevent gas permeation and improve battery cooling efficiency. The system's nominal voltage is 350 volts.

An integrated, liquid-cooling tray circulating 1.82 gallons (6.9 liters) of DEXCOOL™ coolant handles the cooling of the high-voltage battery. The battery pack also has a separate heating element for warm-ups in colder climates, as well as an automatic shut-off relay integrated into its wiring for emergencies.

CONTINUED ON PAGE 6

Flexible, high current, copper positive and negative bus bars connect each battery section together in series. Manual service disconnect removal physically interrupts the series circuit within the battery assembly. During high-voltage battery service, be sure to identify the correct location for each bus bar prior to disassembly. It is possible to install some of the bus bars improperly, which can result in a short circuit.

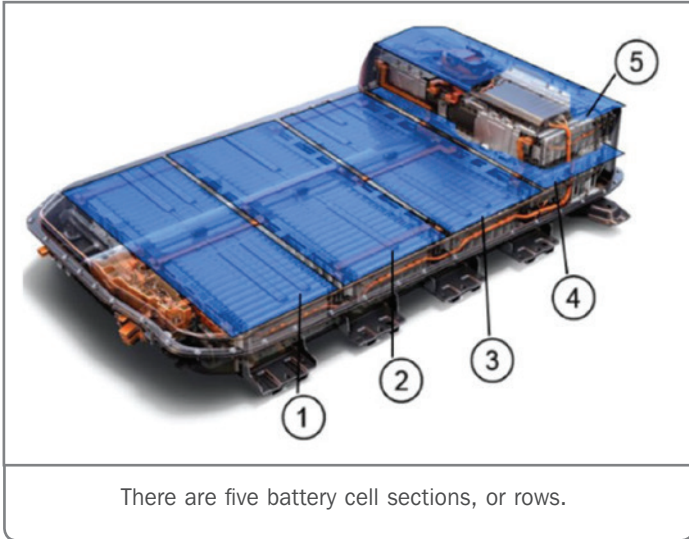

There are five battery cell sections, or rows.

TIP: The separated battery sections are live after system disabling. When servicing the internal battery components, high voltage is exposed. Always take the proper precautions and wear PPE when working in or around the high-voltage battery.

DRIVE MOTOR CONTROL MODULE

The non-serviceable, flash programmable Drive Motor Control Module, contained within the Drive Motor/Generator Power Inverter Module, is controlled by the Hybrid/EV Powertrain Control Module 1. The Drive Motor Control Module controls the speed, direction, and output torque of the drive motor. The scan tool can communicate directly with the Drive Motor Control Module in order to retrieve data parameters only. Associated DTCs are set in the Hybrid/EV Powertrain Control Module 1.

HYBRID/EV POWERTRAIN CONTROL MODULE 1

The Hybrid/EV Powertrain Control Module 1, located in the Power Inverter Module, is the main controller of the powertrain. The Hybrid/EV Powertrain Control Module 1 determines when to perform normal operating modes and regenerative braking. Power modes can be displayed on the infotainment screen by selecting the leaf icon.

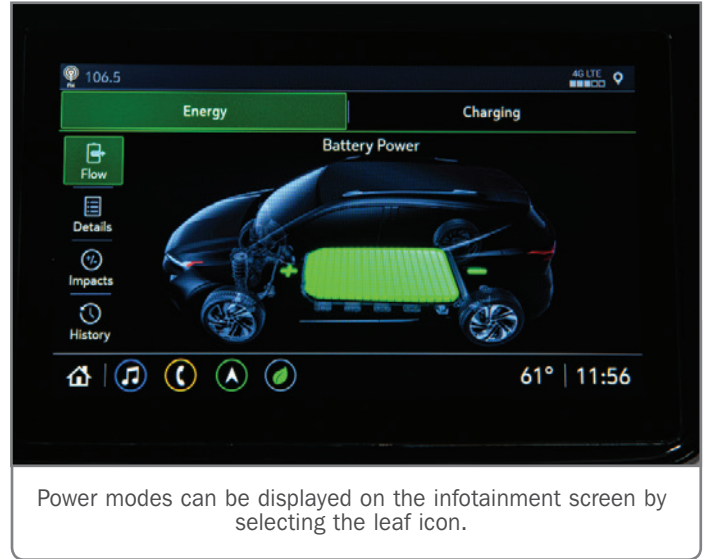

Power modes can be displayed on the infotainment screen by selecting the leaf icon.

The Hybrid/EV Powertrain Control Module 1 also operates in conjunction with the Hybrid/EV Powertrain Control Module 2 to determine when to enable and disable the DC high-voltage circuits. The Hybrid/EV Powertrain Control Module 1 sends commands to the Drive Motor Control Module to operate the applicable motor.

HYBRID/EV POWERTRAIN CONTROL MODULE 2

The Hybrid/EV Control Module 2, located inside the cabin, performs a number of functions, including processing information sent from the Battery Energy Control Module to learn the battery capacity, battery state of charge, and thousands of parameters as the high-voltage battery pack is discharged and charged.

BATTERY ENERGY CONTROL MODULE

The Battery Energy Control Module (BECM) is internal to the high-voltage battery. The BECM collects temperature information from six sensors mounted to specific battery modules, as well as voltage from each cell group, through volt sense wires and total system current. Replacing the BECM requires a specific sequence to disconnect and reconnect in order to prevent internal damage due to voltage spikes.

DRIVE MOTOR BATTERY CHARGER

The on-board drive motor battery charger is located above the transmission and provides the mounting for the Accessory Power Module. The charger can create a maximum output of 11 kW during level 2 charging at 48 amps when running on a 60-amp circuit. The vehicle can achieve a full charge in about 7 hours with a hard-wired 48-amp charger vs. 10 hours using the 32-amp level

CONTINUED ON PAGE 7



Charging options can be selected on the infotainment screen.

2 portable dual-mode charge cord. The level 1 portable cord set can take significantly longer and is intended only for situations

where it is not possible to access a level 2 charge cord. Charging options can be selected on the infotainment screen.

When using the portable dual-mode charge cord:

- For level 1 charging, it is recommended to use a dedicated 20-amp outlet and ensure the charge rate limit is set to the 12-amp rate using the energy display. Location-based charging must be activated in order to achieve 12 amp charging.
- For level 2 charging, it is recommended to use a dedicated 50 amp outlet. At this level, the range yield will be about 25 miles (40 kilometers) per hour of charging.

For level 2 charging using a hard-wired 240V charge station with a dedicated outlet sized appropriately for the charger, set at 48 amps, the range yield will be about 37 miles (60 kilometers) per hour of charging.

For additional information, refer to Bulletin #21-NA-141.

► Thanks to Jonathan Johnson and Matt Bunting

Report Concerns to the 2022 Bolt EUV and Bolt EV TAC Action Center

The GM Technical Assistance Center, or TAC, (U.S.) has established an Action Center for the all-new 2022 Chevrolet Bolt EUV and 2022 Bolt EV.

TAC Action Centers are designed to gather early product feedback and provide support for the introduction of new GM models. Dealership service departments are asked to report all vehicle issues that require immediate attention, not just concerns that require technical assistance. The goal is to develop a quick resolution to any product concerns, such as fit and finish, performance, and operation, as well as to address customer expectations of the vehicle.

TAC Action Centers have a direct connection to GM Engineering, Brand Quality and the assembly plant, which offer combined resources to immediately address product concerns seen in the dealership.

CONTACTING THE TAC ACTION CENTER

If any concerns are encountered with a new Bolt EUV or Bolt EV in your dealership, create a TAC case using the Dealer Case Management (DCM) system. Refer to the latest version of

Bulletin #08-00-89-014 for more information on using the DCM system.

Once a case has been submitted, your concern will be answered by a Bolt specialist who will provide diagnostic direction as needed through the DCM system. After a case has been started, feel free to contact the TAC if any additional support is needed.

Service department personnel are encouraged to report all product concerns and provide digital photos of a concern when possible. Photos are extremely important to show engineering where the concern is located.

In addition, it's imperative to follow up on an action center case, even if it's as simple as a "cannot duplicate" concern or waiting for parts. All case information is reviewed daily and used by GM to resolve launch issues as quickly as possible.

LEARN MORE

For additional information on the 2022 Bolt EUV and Bolt EV, refer to Bulletin #21-NA-141 and the Bolt EUV New Model Launch course 10322.73W.

► Thanks to Jonathan Johnson

Electronic Transmission Range Selector

ASSEMBLY PARTS RETURN

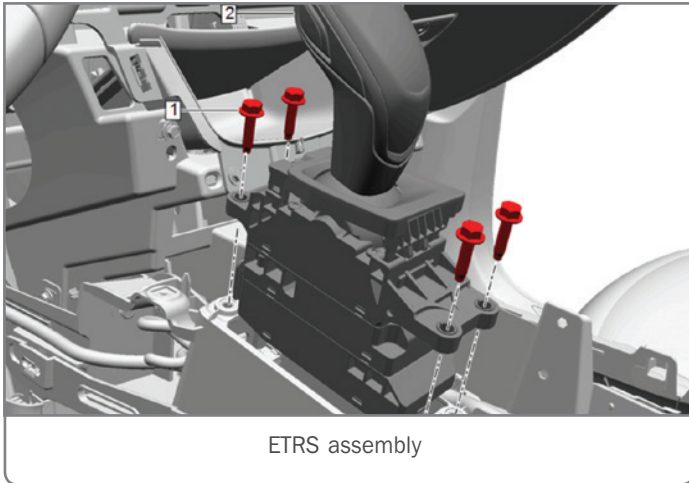

If diagnosis for a transmission condition leads to the replacement of the Electronic Transmission Range Selector (ETRS) assembly on 2020-2022 CT4, CT5, XT4, XT5, XT6; and 2021-2022 Escalade models, keep in mind that the assembly is only serviced as a complete unit. The shift knob is not serviced separately and there are not any internal components that can be repaired in the dealership. The ETRS system does not have any mechanical linkage to the transmission.

Do not attempt to remove any of the parts of the ETRS assembly



when making repairs. When requested by the Warranty Parts Center (WPC), the assembly should be returned as a complete unit. If the assembly is in several pieces or is damaged, it prevents the unit from being tested as part of the engineering investigation for a root cause of failure. Do not attempt to take the assembly apart or make any repairs to the unit.

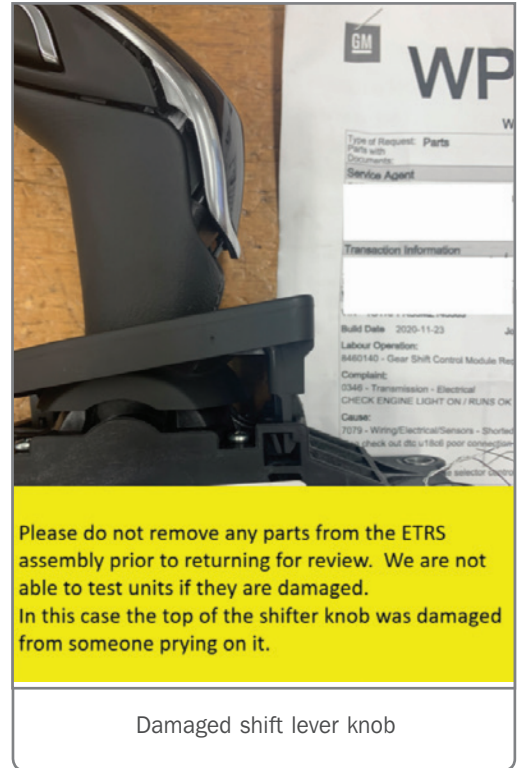

Shown are examples of parts received at the WPC that could not be tested for internal failures. One assembly had the top of the shift lever knob removed, damaging the unit.

In another example, the shift lever knob was damaged by prying on it in order to remove it from the unit.

Refer to the appropriate Service Information for more details on ETRS assembly diagnosis and repairs. If the ETRS assembly is replaced, it may be necessary to perform programming and setup procedures for the Gear Shift Control Module.

▶ Thanks to Tom Burlingame

Proper Key Fob Inspection and Battery Replacement

Any time the Remote Keyless Entry (RKE) transmitter (key fob) on 2017-2022 GM vehicles is opened, such as when inspecting the fob for proper operation or replacing the battery, the fob case must be sealed properly during reassembly. If the fob case is not assembled correctly, the water seal may be pinched, leading to an ineffective seal and possible fob failure.

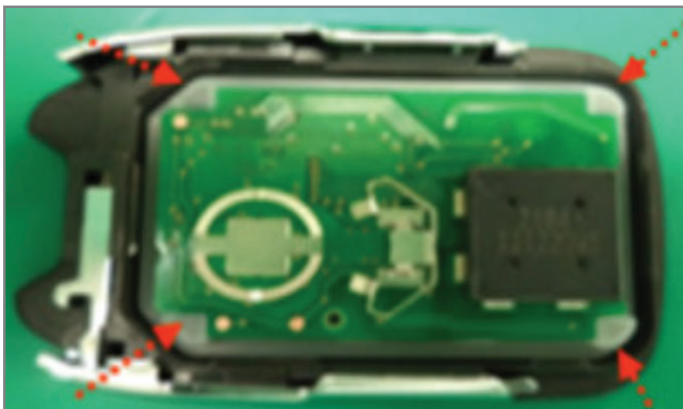

The silicon mat should be correctly positioned with no gaps or wrinkles.

After opening the fob, follow these steps to reassemble the fob:

1. Ensure that the silicon mat is correctly positioned with no gaps or wrinkles. Set the fob, button side down, on a hard surface.



Make sure the cover is properly seated and the seal is not pinched.

2. Align the emblem cover side of the fob on top of the button side of the fob. Make sure it is properly seated and the seal is not pinched.



Snap the cover together by pressing down with your palm.

3. Snap the cover together by pressing down with your palm.

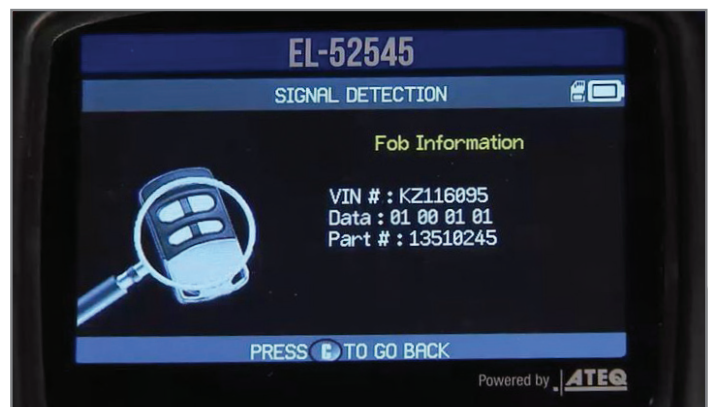

Signal Detection screen

TIP: All 2017-2022 GM vehicles equipped with Remote Keyless Entry/Passive Entry (RPO ATH) and Keyless Open/Start (RPO AVJ) must follow the new warranty requirement outlined in Bulletin #21-NA-068 for key fob warranty claims. To address the number of mismatched key fobs, the requirements include GM authorization for key fob replacement along with a photo of the Signal Detection screen from the EL-52545 TPMS and RF Tool confirming that the VIN of the fob matches the service vehicle listed on the job card (repair order).

For additional information, refer to Bulletin #21-NA-162.

► Thanks to Mike Waszczenko

Wireless Phone Charging Option

NO LONGER AVAILABLE ON SOME 2021 MODELS

The Wireless Phone Charging option is no longer available on most 2021 Tahoe, Suburban and Yukon models beginning in July 2021 due to the industry-wide shortage of semiconductors. The wireless charging pad is located at the front of the center console.



The wireless phone charging pad is located in the center console.

Affected vehicles will have the added RPO 00C (Not Equipped with Wireless Charging). RPO 00C will be used to identify vehicles built without the wireless phone charging capability. Wiring, connectors and fuses related to wireless charging functions will remain unchanged.

The wireless charging pad mat with the charging graphic will be removed from the center console. The wireless charging module

will be replaced with a non-functioning communications module that will not be capable of the wireless charging function.



Wireless charging pad

Any vehicle that includes RPO 00C is not equipped with wireless phone charging technology, even though the vehicle also includes RPO K4C (Wireless Charging), which is retained based on other components that remain on the vehicle. Any vehicle with RPO 00C and RPO K4C cannot be updated to restore the wireless charging functionality.

These production changes regarding the availability of wireless phone charging are currently expected to remain in place for the remainder of the 2021 model year.

► Thanks to Hassan Abdallah

3.6L Engine Intake Camshaft Position DTCs

Some 2021 Camaro models equipped with the 3.6L V6 engine (RPO LGX) may have an illuminated Check Engine MIL and DTCs P0011 (Intake Camshaft Position System Performance Bank 1) and/or P0016 (Crankshaft Position – Intake Camshaft Position Not Plausible Bank 1) set in the Engine Control Module. These conditions are usually found on new vehicles with less than 150 miles.

If these DTCs are set, check the intake camshaft position actuator solenoid connectors. Unplug each connector and inspect for any damage. Securely reconnect the connectors, clear the DTCs and test drive the vehicle. If the DTCs return, follow the diagnostic procedures in the appropriate Service Information. Do not replace the intake camshaft position actuator solenoids.

Refer to #PIP5815 for additional information.

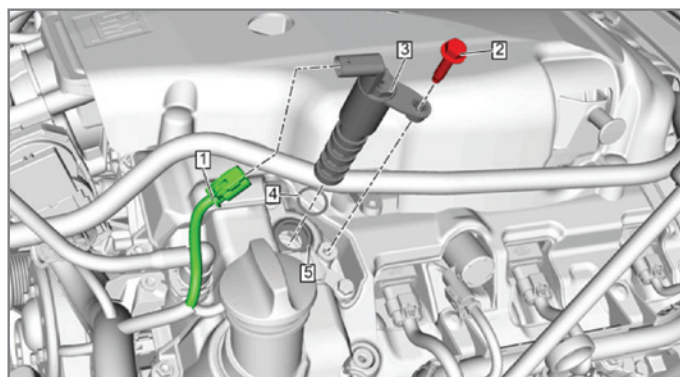

Check the intake camshaft position actuator solenoid connectors

► Thanks to Aron Wilson

Heater Outlet Pipe Coolant Leak

A coolant leak or coolant smell at the front passenger-side of the vehicle may be noticed on some 2019-2021 Silverado 4500HD/5500HD/6500HD models equipped with the 6.6L Duramax diesel engine (RPO L5D). The coolant leak may be caused by a cracked heater outlet pipe along the lower bracket weld. Check for a coolant leak at the heater outlet pipe.

If the coolant leak is coming from the heater outlet pipe, a new, redesigned pipe is now available. Replace the pipe, bracket and clamp. Be sure to torque all fasteners to specification. After filling

the cooling system, check for any leaks before completing the repairs.

If coolant is not leaking from the heater outlet pipe, refer to engine cooling diagnostics in the appropriate Service Information.

Refer to Bulletin #21-NA-143 for more details and parts information.

► Thanks to Bob Briedis

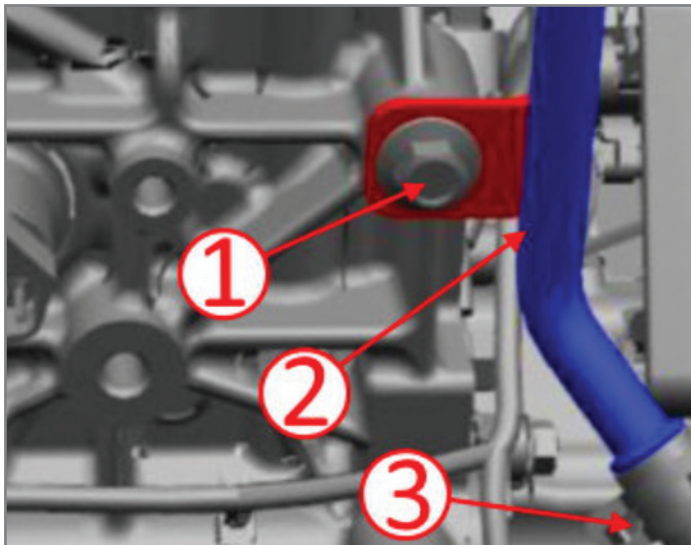

Check for a leak at the heater outlet pipe along the lower bracket weld.

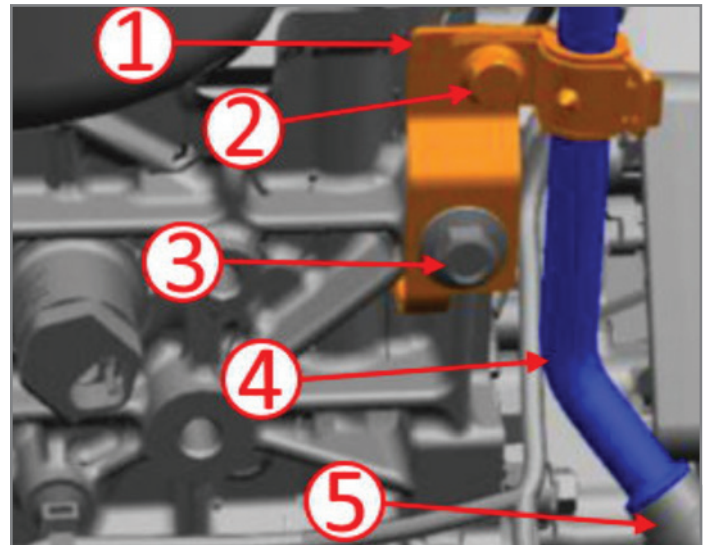

Redesigned tube, bracket and clamp

TECH LINK

GM TechLink is published for all GM retail technicians and service consultants to provide timely information to help increase knowledge about GM products and improve the performance of the service department.

Publisher:
Michael O'Hare
GM Customer Care and Aftersales

Editor:
Lisa G. Scott
GM Customer Care and Aftersales

Technical Editor:
Mark Spencer
mspencer@gpstrategies.com

Production Manager:
Marie Meredith

Creative Design:
5by5 Design LLC
dkelly@5by5dzign.com

Write to:
TechLink
PO Box 500, Troy, MI 48007-0500

GM TechLink on the Web:
GM GlobalConnect

General Motors service tips are intended for use by professional technicians, not a "do-it-yourselfer." They are written to inform those technicians of conditions that may occur on some vehicles, or to provide information that could assist in the proper service of a vehicle. Properly trained technicians have the equipment, tools, safety instructions and know-how to do a job properly and safely. If a condition is described, do not assume that the information applies to your vehicle or that your vehicle will have that condition. See a General Motors dealer servicing your brand of General Motors vehicle for information on whether your vehicle may benefit from the information. Inclusion in this publication is not necessarily an endorsement of the individual or the company. All information contained herein is based on the latest information available at the time of publication and is subject to change without notice. Copyright © 2021 General Motors. All rights reserved.